

---

# Protection Relay Testing and Commissioning

Course No: E06-004

Credit: 6 PDH

---

Velimir Lackovic, Char. Eng.

---



Continuing Education and Development, Inc.  
22 Stonewall Court  
Woodcliff Lake, NJ 07677

P: (877) 322-5800  
[info@cedengineering.com](mailto:info@cedengineering.com)

---

## **PROTECTION RELAY TESTING AND COMMISSIONING**

The testing and verification of protection devices and arrangements introduces a number of issues. This happens because the main function of protection devices is related to operation under fault conditions so these devices cannot be tested under normal operating conditions. This problem is worsened by the growing complexity of protection arrangements, application of protection relays with extensive software functionalities, and frequently used Ethernet peer-to-peer logic. The testing and verification of relay protection devices can be divided into four groups:

- Routine factory production tests
- Type tests
- Commissioning tests
- Occasional maintenance tests

### **TYPE TESTS**

Type tests are needed to prove that a protection relay meets the claimed specification and follows all relevant standards. Since the basic function of a protection relay is to correctly function under abnormal power conditions, it is crucial that the operation is evaluated under such conditions. Therefore, complex type tests simulating the working conditions are completed at the manufacturer's facilities during equipment development and certification. The standards that cover majority of relay performance aspects are IEC 60255 and IEEE C37.90. Nevertheless, compliance may also include consideration of the demands of IEC 61000, 60068 and 60529, while products intended for installation in the EU also have to comply with the requirements of EU Directives. Since type testing of a digital or numerical protection relay includes software and hardware testing, the type testing procedure is very complex and more challenging than a static or electromechanical relay.

### **ROUTINE FACTORY PRODUCTION TESTS**

These tests are done to show that protection relays are free from defects during manufacturing process. Testing will be done at several stages during manufacture, to make sure problems are discovered at the earliest possible time and therefore minimize remedial work. The testing extent will be impacted by the relay complexity and past manufacturing experience.

## COMMISSIONING TESTS

Commissioning tests are done to show that a particular protection configuration has been correctly used prior to setting to work. All aspects of the configuration are thoroughly verified, from installation of the correct equipment through wiring verifications and operation checks of the equipment individual items, finishing with testing of the complete configuration.

## PERIODIC MAINTENANCE VERIFICATIONS

These are needed to discover equipment failures and service degradation, so that corrective action can be taken. Because a protection configuration only works under fault conditions, defects may not be discovered for a substantial period of time, until a fault happens. Regular testing assists in discovering faults that would otherwise stay undetected until a fault happens.

## ELECTRICAL TYPE TESTS

Different electrical type tests must be completed, as follows:

## FUNCTIONAL TESTS

The functional tests consist of using the adequate inputs to the protection relay under test and measuring the performance to discover if it meets the specification. They are typically completed under controlled environmental conditions. The testing may be complex, even where only a simple relay function is being assessed. This can be understood by considering the simple overcurrent relay device shown in Table 1. To check compliance with the specification, the tests presented in Table 2 need to be carried out. This is a time consuming process, involving many engineers and technicians. Therefore, it is expensive.

Element	Range	Step size
I>1	0.08-4.00 I <sub>n</sub>	0.01 I <sub>n</sub>
I>2	0.08-32 I <sub>n</sub>	0.01 I <sub>n</sub>
Directionality	Forward/Reverse/Non-directional	
RCA	-95° to 95°	1°
Characteristic	DT/IDMT	
Definite Time Delay	0-100 s	0.01 s
IEC IDMT Time Delay	IEC Standard Inverse	

Element	Range	Step size
	IEC Very Inverse IEC Extremely Inverse IEC Long Time Inverse	
Time Multiplier Setting (TMS)	0.025-1.2	0.005
IEEE IDMT Time Delay	IEEE Moderately Inverse IEEE Very Inverse IEEE Extremely Inverse US-CO8 Inverse US-CO2 Short Time Inverse	
Time Dial (TD)	0.5-15	0.1
IEC Reset Time (DT only)	0-100 s	0.01 s
IEEE Reset Time	IDMT/DT	
IEEE DT Reset Time	0-100 s	0.01 s
IEEE IDMT Reset Time	IEEE Moderately Inverse IEEE Very Inverse IEEE Extremely Inverse US-CO8 Inverse US-CO2 Short Time Inverse	

Table 1. Overcurrent relay device specification

Test no.	Description
Test 1	Three phase non-directional pickup and drop off accuracy over complete current setting range for both stages
Test 2	Three phase directional pick up and drop off accuracy over complete RCA setting range in the forward direction, current angle sweep
Test 3	Three phase directional pick up and drop off accuracy over complete RCA setting range in the reverse direction, current angle sweep
Test 4	Three phase directional pick up and drop off accuracy over complete RCA setting range in the forward direction, voltage angle sweep
Test 5	Three phase directional pick up and drop off accuracy over complete RCA setting range in the reverse direction, voltage angle sweep
Test 6	Three phase polarizing voltage threshold test
Test 7	Accuracy of DT timer over complete setting range
Test 8	Accuracy of IDMT curves over claimed accuracy range
Test 9	Accuracy of IDMT TMS/TD
Test 10	Effect of changing fault current on IDMT operating times
Test 11	Minimum pick-up of starts and trips for IDMT curves
Test 12	Accuracy of reset timers
Test 13	Effect of any blocking signals, VTS, autoreclose
Test 14	Voltage polarization memory

Table 2. Overcurrent relay element functional type tests

When a modern numerical protection relay with many functions is assessed, each of which has to be type-tested, the functional type-testing involved is significant issue. In the case of a recent relay development project, it was found that if one person had to complete all the work, it would take 4 years to write the functional type-test specifications, 30 years to complete the tests and several years to write the test reports. Automated processes and equipment are clearly needed.

## **RATING TESTS**

Rating type tests are completed to make sure that components are used within their defined ratings and that there is no fire or electric shock hazards under a normal load or fault conditions. Also, this is done along with verification that the product follows its technical specification. The following are the rating type tests done on protection relays. They are defined in IEC 60255-1.

## **THERMAL WITHSTAND TESTS**

The thermal withstand of VTs, CTs and output contact circuits are done to ensure compliance with the defined continuous and short-term overload conditions. In addition to functional check, the pass criterion is that there is no damaging effect on the relay assembly, or circuit elements, when the product is exposed to overload conditions that may be expected. Thermal withstand is evaluated over a time period of 1s for CTs and 10s for VTs.

## **RELAY BURDEN TEST**

The auxiliary supply burdens, optically isolated inputs, VTs and CTs are measured to determine that the product complies with its specification. The burden of products with a big number of input/output circuits is application specific i.e. it increases according to the number of optically isolated input and output contact ports which are energized under normal power system load conditions. It is typically believed that not more than 50% of these ports will be simultaneously energized in any installation.

## **RELAY INPUTS**

Relay inputs are verified over the specified ranges. Inputs include those for auxiliary voltage, VT, CT, frequency, optically isolated digital inputs and communication elements.

## **RELAY OUTPUT CONTACTS**

Protection relay output contacts are type tested to make sure that they follow product specification. Special withstand and endurance type tests have to be completed using DC, since the normal supply is via a station battery.

## **INSULATION RESISTANCE TEST**

The insulation resistance test is completed in line with IEC 60255-27, i.e. 500V DC. - 10%, for a minimum of 5 seconds. This is completed between all circuits and case ground, between all independent circuits and across normally open contacts. The pass criterion for a product in new condition is a minimum of 100M $\Omega$ . After a damp heat test the pass criterion is a minimum of 10M $\Omega$ .

## **AUXILIARY SUPPLIES**

Digital and numerical protection relays typically need an auxiliary supply to give power to the on board microprocessor circuitry and the interfacing opto-isolated input circuits and output protection relays. The auxiliary supply can be either AC. or DC, powered from a number of sources or safe supplies. These supplies include batteries, UPSs and they may be subject to voltage dips, short interruptions and voltage fluctuations. Protection relays are made to ensure that service is kept and no damage happens during a disturbance of the auxiliary supply. Tests are completed for both AC. and DC. auxiliary supplies and include mains change both above and below the nominal rating, supply interruptions derived by open circuit and short circuit, power dips as a percentage of the nominal supply, repetitive starts. The interruption duration and supply dips range from 2ms to 60s intervals. A short supply interruption or dip up to 20ms, potentially longer, should not start relay malfunction. Malfunctions include the operation of output relays and watchdog contacts, the reset of microprocessors, alarm or trip indication, acceptance of corrupted information over the communication link and

the corruption of saved information or settings. For a longer supply interruption, or dip exceeding 50ms, the protection relay self recovers without the loss of any function, information, settings or information corruption. No operator intervention is needed to restore operation after an interruption or supply dip. In addition to the above, the protection relay is exposed to a number of repetitive starts or a sequence of supply interruptions. Again the protection relay is tested to make sure that no damage or data corruption has happened during the repetitive tests. Specific tests completed on DC, auxiliary supplies include reverse polarity, AC. waveform superimposed on the DC, supply and the effect of an increasing and decaying auxiliary voltage. All tests are completed at different loading levels of the relay auxiliary supply.

## **ELECTROMAGNETIC COMPATIBILITY TESTS**

There are different tests that are completed to check the ability of protection relays to withstand the electrical environment in which they are put. The substation environment is a very severe environment in terms of the electrical and electromagnetic interference that can happen. There are many sources of interference within a substation, some developing internally, others being conducted along the transmission lines or cables into the substation from external disturbances. The most typical sources are:

- system faults
- switching operations
- conductor flashover
- lightning strikes
- telecommunication operations e.g. mobile phones

A whole suite of tests are completed to simulate these types of interference, and they fall under the broad umbrella of what is known as EMC or Electromagnetic Compatibility tests. Broadly speaking, EMC can be specified as: 'The ability of various devices to co-exist in the same electromagnetic environment'. This is not a new topic and has been examined by the military ever since the advent of electronic equipment. EMC can cause severe problems, and does need to be considered when making electronic equipment. EMC tests check the impact on the protection relay under test of high-frequency electrical disturbances. Protection relays produced or intended for

application in the EU have to follow Directive 2004/108/EC. To accomplish this, in addition to designing for statutory compliance to this Directive, the following range of tests is completed:

- DC interrupt test
- fast transient test
- AC ripple on DC supply test
- high frequency disturbance test
- DC ramp test
- power frequency interference test
- surge immunity test
- conducted and radiated emissions tests
- electrostatic discharge test
- magnetic field tests
- conducted and radiated immunity tests

#### **D.C INTERRUPT TEST**

This is a test to check the maximum length of time that the protection relay can withstand an interruption in the auxiliary supply without de-energizing, e.g. switching off, and that when this time is surpassed and it does transiently switch off, that no maloperation happens. It models the impact of a loose fuse in the battery circuit, or a short circuit in the common DC supply, interrupted by a fuse. Another DC interruption source is if there is a power system fault and the battery is powering both the protection relay and the circuit breaker trip coils. When the battery energizes the coils to start the circuit breaker trip, the voltage may decrease below the needed level for operation of the protection relay. Therefore a DC interrupt happens. The test is defined in IEC 60255-11 and comprises interruptions of 10, 20, 30, 50, 100, 200, 300, 500, 1000, and 5000ms. For interruptions lasting up to and including 20ms, the protection relay must not de-energize or maloperate, while for longer interruptions it must not maloperate. Many modern devices are capable of staying energized for interruptions up to 50ms. The protection relay is supplied from a battery supply, and both short circuit and open circuit interruptions are completed. Each interruption is applied 10 times, and for auxiliary power supplies with a big operating range, the tests are completed at



minimum, maximum, and other voltages across this range, to check compliance over the complete range.

### **A.C. RIPPLE ON D.C. SUPPLY**

This test (IEC 60255-11) checks that the protection relay is able to correctly function with a superimposed AC voltage on the DC supply. This is caused by the station battery being charged by the battery charger, and the waveform is presented in Figure 1. It comprises a 15% peak-to-peak ripple superimposed on the DC supply voltage.

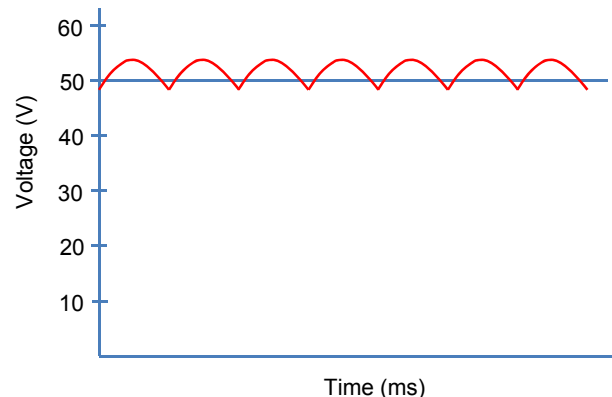

Figure 1. AC ripple laid over DC supply test voltage

For auxiliary power supplies with a big operating range, the tests are completed at minimum, maximum, and other voltages across this range, to verify compliance for the complete range. The interference is applied using a complete wave rectifier network, connected in parallel with the battery supply. The protection relay must continue to work without malfunction during the test.

### **D.C. RAMP DOWN/RAMP UP TEST**

This test models a failed station battery charger, which would end in the auxiliary voltage to the relay slowly ramping down. The ramp up part models the battery being recharged after discharging. The protection relay must cleanly power up when the voltage is applied and not maloperate. There is no internationally accepted standard for this test, so manufacturers can determine if they want to complete such a test and what the test specification shall be.

## HIGH FREQUENCY DISTURBANCE TEST

The high frequency disturbance test models high voltage transients that result from power system faults and plant switching operations. It comprises a 1MHz decaying sinusoidal waveform, as presented in Figure 2. The interference is applied across each independent circuit (differential mode) and between each independent circuit and ground (common mode) via an external coupling and switching network. The product is energized in both normal (quiescent) and tripped modes, and must not malfunction when the interference is applied for 2 seconds.

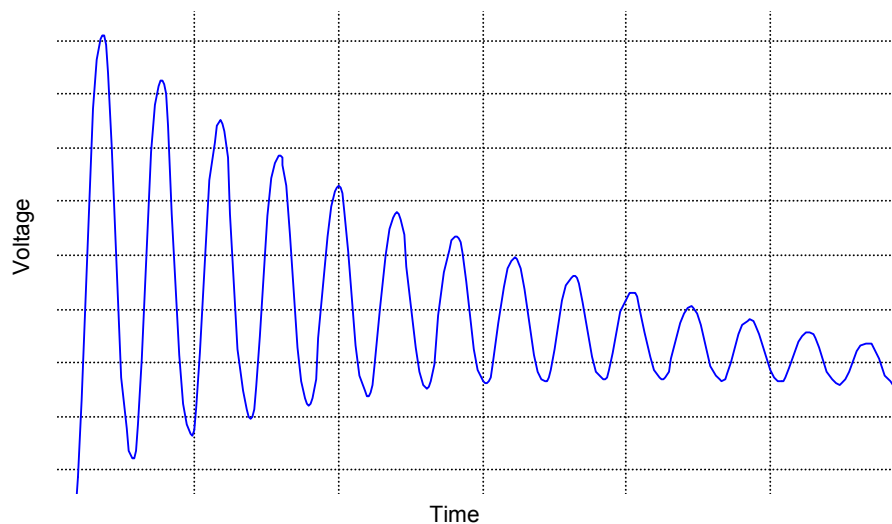

Figure 2. High frequency disturbance test waveform

## FAST TRANSIENT TEST

The Fast Transient Test models the HV interference caused by disconnector GIS substations operations or breakdown of the SF6 insulation between conductors and the grounded enclosure. This interference can either be inductively coupled onto protection relay circuits or can be directly introduced via the CT or VT inputs. It comprises a series of 15ms duration bursts at 300ms intervals, each burst comprising a train of 50ns wide pulses with very fast (5ns typical) rise times (as presented in Figure 3), with a peak voltage magnitude of 4kV.

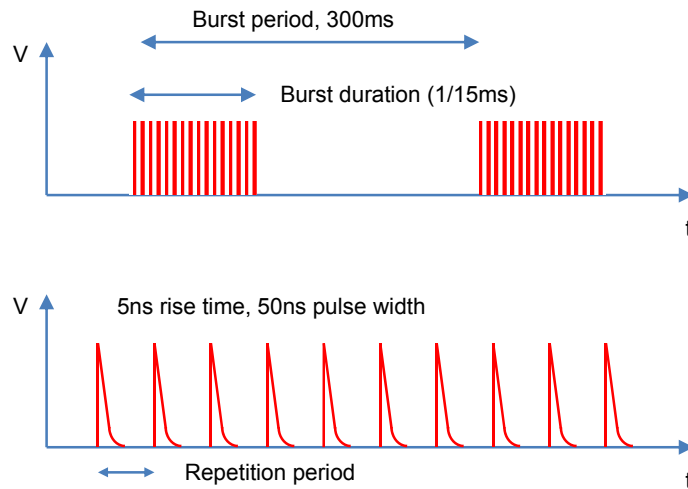

Figure 3. Fast transient test waveform

The product is energized in both normal (quiescent) and tripped modes. It must not malfunction when the interference is applied in common mode via the integral coupling network to each circuit in turn, for 60 seconds. If needed, interference is coupled onto communications circuits by applying an external capacitive coupling clamp.

### **SURGE IMMUNITY TEST**

The surge immunity test models interference created by major power system disturbances such as capacitor bank switching and lightning strikes on transmission lines within 5km of the substation. The test waveform has an open circuit voltage of 4kV for common mode surges and 2kV for differential mode surges. The wave shape comprises an open circuit of a 1.2/50<sub>s</sub> rise/fall time and a short circuit current of 8/20<sub>s</sub> rise/fall time. The generator can provide a short circuit test current of up to 2kA, making this test potentially damaging. The surges are consecutively used under software control via dedicated coupling networks in both differential and common modes with the product energized in its normal (quiescent) state. The product shall not malfunction during the test, shall still work within specification after the test sequence and shall not get any permanent damage.

## **POWER FREQUENCY INTERFERENCE TEST**

This test models the interference type that is caused when there is a power system fault and very high levels of fault current flow in the primary conductors or the ground grid. This creates 50 or 60Hz interference in control and communications circuits. There is no universally accepted international standard for this test, but one used by some utilities is:

- 250V r.m.s., differential mode used for circuits for which power system inputs are not connected
- 500V r.m.s., common mode

Tests are completed on each circuit, with the protection relay in the following operation modes:

- current and voltage applied at 110% of setting, (relay tripped)
- current and voltage applied at 90% of setting, (relay not tripped)
- main protection and communications functions are verified to check the interference effect. The protection relay shall not maloperate during the test, and shall still complete its main functions within the claimed tolerance.

## **ELECTROSTATIC DISCHARGE TEST**

This test models the type of high voltage interference that happens when an operator touches the protection relay's front panel after being charged to a high potential. In this situation the discharge is applied to the relay front panel, with the cover both on and off. Two types of discharges are used, air discharge and contact discharge. Air discharges are applied on surfaces that are typically insulators, and contact discharges are applied on surfaces that are typically conducting. IEC 60255-22-2 is the adequate standard for this test. Typical test parameters are:

- cover off: Class 3, 6kV contact discharge, 8kV air discharge
- cover on: Class 4, 8kV contact discharge, 15kV air discharge

In either case, all the lower test levels are also tested. The discharge current waveform is presented in Figure 4.

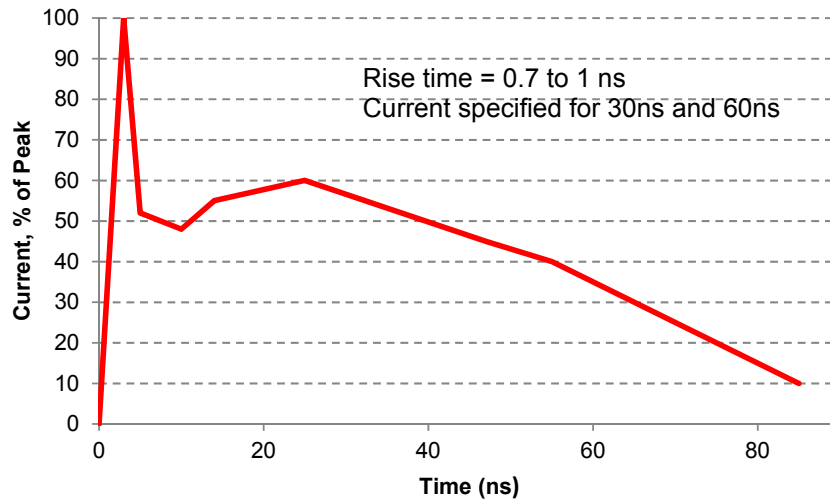

Figure 4. ESD current waveform

The test is completed with single discharges repeated on each test point 10 times with positive polarity and 10 times with negative polarity at each test level. The time interval between consecutive discharges is higher than 1 second. Tests are completed at each level, with the protection relay in the following operation modes:

- current and voltage applied at 110% of setting, (relay tripped)
- current and voltage applied at 90% of setting, (relay not tripped)
- main protection and communications functions are checked to verify the discharge effect. To pass, the protection relay shall not maloperate, and shall still complete its main functions within the claimed tolerance.

## CONDUCTED AND RADIATED EMISSIONS TESTS

These tests come up from the basic protection demands of the EU directive on EMC. These demand that manufacturers ensure that any equipment must not interfere with other equipment. To accomplish this it is necessary to evaluate the emissions from the equipment and check that they are below the prescribed limits. Conducted emissions are evaluated only from the equipment's power supply ports and are to ensure that when connected to a mains network, the equipment does not send interference back into the network which could affect the other equipment installed in the network. Radiated emissions measurements are to make sure that the interference emitted from the equipment is not at a level that could cause interference to other devices.

This test is typically completed on an Open Area Test Site (OATS) where there are no reflecting structures or radiation sources. Hence, the completed measurements are proper indication of the emission spectrum of the protection relay. An example of a plot got during completed emissions tests is presented in Figure 5.

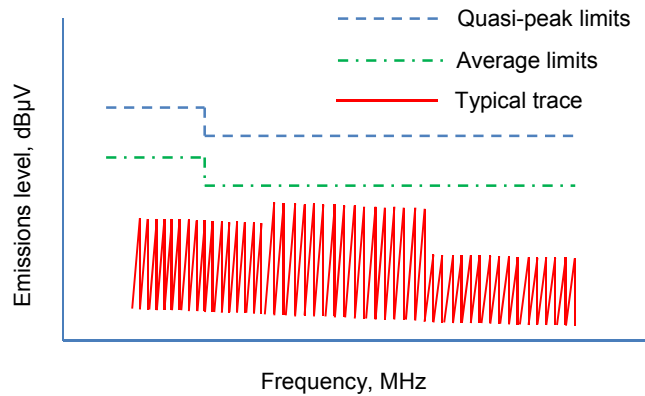

Figure 5. EMC conducted emissions test

The test configurations for the conducted and radiated emissions tests are presented in Figure 6.

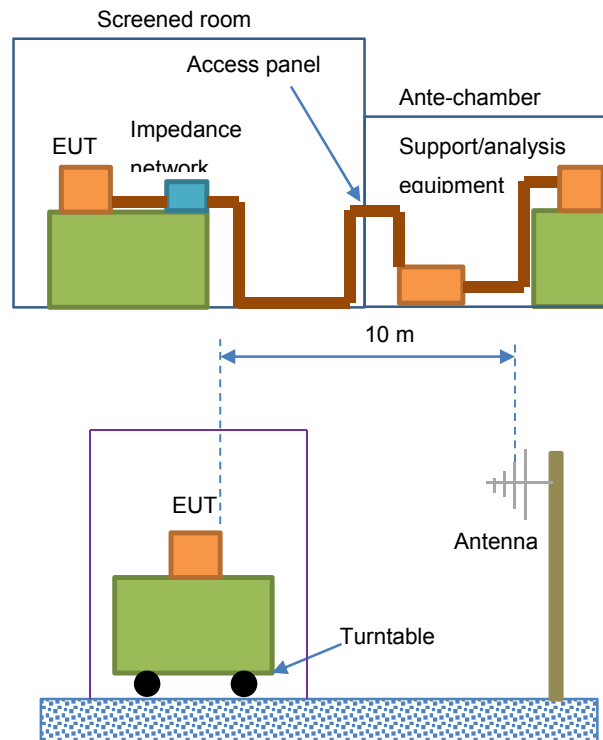

Figure 6. EMC test configurations (a) Conducted EMC emissions test configuration  
(b) Radiated emissions test configuration on an OATS

When completing these two tests, the protection relay is in a quiescent condition, that is not tripped, with currents and voltages applied at 90% of the setting values. This is done because for the majority of its life, the protection relay will be in the quiescent state and the emission of electromagnetic interference when the protection relay is tripped is considered to be of no significance. Tests are completed following IEC 60255-25 and EN 55022, and are described in Table 3.

	Frequency range	Specified limits	Test limits
Radiated	30-230 MHz	30dB(μV/m) at 30m	40dB(μV/m) at 10m
Radiated	230-1000 MHz	37dB(μV/m) at 30m	47dB(μV/m) at 10m
Conducted	0.15-0.5 MHz	79 dB(μV) quasi-peak 66 dB(μV) average	79 dB(μV) quasi-peak 66 dB(μV) average
Conducted	0.5-30 MHz	73 dB(μV) quasi-peak 60 dB(μV) average	73 dB(μV) quasi-peak 60 dB(μV) average

Table 3. Test standards for conducted and radiated emissions tests

## CONDUCTED AND RADIATED IMMUNITY TESTS

These tests are done to make sure that the equipment is immune to interference levels that it may be exposed to. The two tests, conducted and radiated, come up from the fact that for a conductor to be an efficient antenna, it must have a length of at least ¼ of the wavelength of the electromagnetic wave it is required to transfer. If a protection relay were to be exposed to radiated interference at 150kHz, then a conductor length of at least

$$\lambda = \frac{300 \times 10^6}{(150 \times 10^3 \times 4)} = 500 \text{ m}$$

would be required to conduct the interference. Even with all the cabling attached and with the longest PCB track length taken into consideration, it would be highly unlikely that the protection relay would be able to transfer radiation of this frequency. Hence, the test would have no effect. The interference has to be physically introduced by conduction, therefore the conducted immunity test. Nevertheless, at the radiated immunity lower frequency limit of 80MHz, a conductor length of roughly 1.0m is needed. At this frequency, radiated immunity tests can be completed with the confidence that the protection relay will transfer this interference, through a combination of the attached cabling and the PCB tracks. Even though the test

standards state that all 6 faces of the equipment should be exposed to the interference, in reality this is not done. Applying interference to the sides and top and bottom of the protection relay would have little effect as the circuitry inside is effectively screened by the grounded metal case. Nevertheless, the front and rear of the protection relay are not totally enclosed by metal and are therefore not at all well screened, and can be regarded as an EMC hole. Electromagnetic interference when directed at the front and back of the protection relay can freely enter onto the PCBs inside. When completing these two tests, the protection relay is in a quiescent condition, that is not tripped, with currents and voltages applied at 90% of the setting values. This is because for the majority of its life, the protection relay will be in the quiescent state and the coincidence of an electromagnetic disturbance and a fault is believed to be unlikely. Nevertheless, spot checks are completed at chosen frequencies when the main protection and control functions of the protection relay are exercised, to make sure that it will function as expected, should it be needed to do so. The frequencies for the spot verifications are chosen to coincide with the radio frequency broadcast bands, and the frequencies of mobile communications devices used by staff working in the substation. This is to make sure that when working in the vicinity of a protection relay, the staff should be able to operate their radios/mobile phones without fear of protection relay maloperation.

IEC 60255-22-3 defines the radiated immunity tests to be completed (ANSI/IEEE C37.90.2 is used for devices compliant with North American standards), with signal levels of:

- ANSI/IEEE: 35V/m 25MHz - 1000MHz with no modulation, and again with 100% pulse modulation IEC 60255-22-6 is used for the conducted immunity test, with a test level of:
  - IEC: Class III, 10V/m, 80MHz -2700MHz
  - Class III, 10V r.m.s., 150kHz - 80MHz.

## **POWER FREQUENCY MAGNETIC FIELD TESTS**

These tests are completed to make sure that the equipment is immune to magnetic interference. The three tests, steady state, pulsed and damped oscillatory magnetic



field, come up from the fact that for different site circumstances the level and wave shape is changed.

## STEADY STATE MAGNETIC FIELD TESTS

These tests model the magnetic field that would be felt by a device installed within close proximity of the power system. Testing is completed by subjecting the protection relay to a magnetic field created by two induction coils. The protection relay is rotated such that in each axis it is exposed to the full magnetic field strength. IEC 61000-4-8 is the relevant standard, using a signal level of:

- Level 5: 300A/m continuous and 1000A/m short duration

The test configuration is presented in Figure 7.

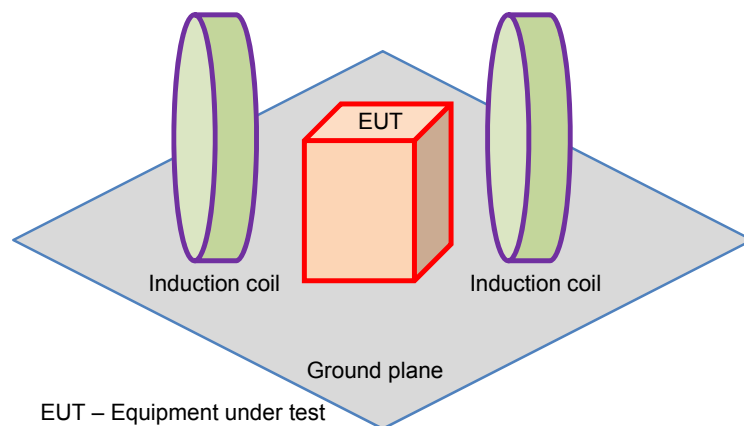

Figure 7. Power frequency magnetic field test configuration

To successfully complete the steady-state test, the protection relay shall not malfunction, and shall still perform its main functions within the specified tolerance. During the application of the short duration test, the main protection function shall be exercised and checked that the relay operating characteristics are unaffected.

## PULSED MAGNETIC FIELD

These tests model the magnetic field that would be felt by equipment installed within close proximity of the power system during a transient fault condition. According to IEC 61000-4-9, the generator for the induction coils shall generate a 6.4/16 $\mu$ s wave

shape with test level 5, 100A/m with the devices configured as for the steady state magnetic field test. The protection relay shall not maloperate, and shall still complete its main functions within the specified tolerance during the test.

### **DAMPED OSCILLATORY MAGNETIC FIELD**

These tests model the magnetic field that would be received by a device installed within close proximity of the power system during a transient fault condition. IEC 61000-4-10 defines that the generator for the coil shall generate an oscillatory wave shape with a frequency of 0.1MHz and 1MHz, to provide a signal level in accordance with Level 5 of 100A/m. The equipment shall be arranged as in Figure 7.

### **PRODUCT SAFETY TYPE TESTS**

A number of tests are completed to show that the product is safe when used for its intended application. The essential demands are that the protection relay is safe and will not cause an electric shock or fire hazard under normal circumstances and in the presence of a single fault. A number of required tests to show this may be completed.

### **DIELECTRIC VOLTAGE WITHSTAND**

Dielectric voltage withstand testing is completed as a routine test i.e. on every unit prior to shipment. The goal of this test is to make sure that the product build is as intended by design. This is accomplished by checking the clearance in air, therefore ensuring that the product is safe to work under normal use conditions. The following tests are completed unless otherwise defined in the product documentation:

- 1.0kV r.m.s., 50/60Hz for 1 minute across the normally open contacts of watchdog or changeover output protection relays, in line with IEC 60255-27 The routine dielectric voltage withstand test time may be shorter than for the 1 minute type test time, to allow a reasonable production throughput.
- 1.5kV r.m.s., 50/60Hz for 1 minute across normally open contacts intended for connection to tripping circuits, in line with ANSI/IEEE C37.90 21-9

- 2.0kV r.m.s., 50/60Hz for 1 minute between all terminals and case ground and also between independent circuits, in line with IEC 60255-27. Some communication circuits are omitted from this test, or have modified test demands e.g. those using D-type connectors

## INSULATION WITHSTAND FOR OVERVOLTAGES

The objective of the high voltage impulse withstand type test is to make sure that circuits and their elements will withstand over-voltages on the power system created by lightning. Three positive and three negative high voltage impulses, 5kV peak, are applied between all circuits and the case ground and also between the terminals of independent circuits. As before, different demands apply in the case of circuits using D-type connectors. The test generator features are described in IEC 60255-27 and are presented in Figure 8. No disruptive discharge (i.e. flashover or puncture) is permitted. If it is mandatory to repeat either the dielectric voltage or high voltage impulse withstand tests. These should be completed at 75% of the defined level, in line with IEC 60255-27, to avert overstressing insulation and components.

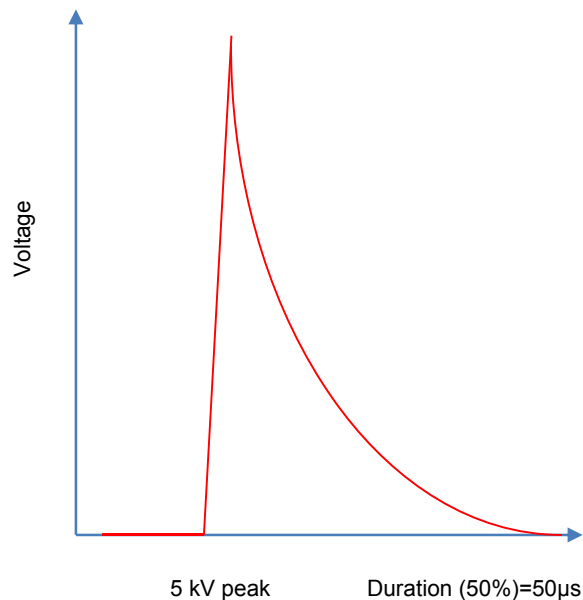

Figure 8. Test generator features for insulation withstand test

## **SINGLE FAULT CONDITION EVALUATION**

Verification is done to understand if a single fault condition such as an overload, or an open or short circuit, applied to the equipment may cause an electric shock or fire hazard. In the case of uncertainty, type testing is completed to make sure that the product is safe.

## **GROUND BONDING IMPEDANCE**

Class 1 products that are based on a protective ground connection for safety are subjected to ground bonding impedance (EBI) type test. This makes sure that the ground path between the protective ground connection and any accessible grounded part is sufficiently low to avoid damage in the case of a single fault. The test is completed using a maximum 12V test voltage and a test current of twice the suggested maximum protective fuse rating. After 1 minute with the current running in the circuit under test, the EBI shall not surpass  $0.1\Omega$ .

## **CE MARKING**

A CE mark on the equipment, or its packaging, indicates that compliance is claimed against relevant EU directives e.g. Low Voltage Directive 2006/95/EC and Electromagnetic Compatibility (EMC) Directive 2004/108/EC.

## **OTHER REGIONAL OR INDUSTRY NORMS**

Many devices intended for installation in North America will need extra certification to meet the requirements of UL (Underwriter's Laboratory), or CUL for Canada. Equipment for installation in mining or explosive environments will typically need to demonstrate an ATEX claim.

## **ENVIRONMENTAL TYPE TESTS**

Different tests have to be completed to show that a protection relay can withstand the environment effects in which it is expected to operate. They consist of the following tests:

- Humidity
- Temperature

- mechanical
- enclosure protection

These tests are discussed in the following paragraphs.

### **TEMPERATURE TEST**

Temperature tests are completed to make sure that a product can withstand extremes in temperatures, both hot and cold, during transit, storage and operating conditions. Storage and transit conditions are specified as a temperature range of  $-25^{\circ}\text{C}$  to  $+70^{\circ}\text{C}$  and operating as  $-25^{\circ}\text{C}$  to  $+55^{\circ}\text{C}$ . Many products now claim operating temperatures of  $+70^{\circ}\text{C}$  or even higher. Dry heat withstand tests are done at  $70^{\circ}\text{C}$  for 96 hours with the protection relay de-energized. Cold withstand tests are completed at  $-40^{\circ}\text{C}$  for 96 hours with the protection relay de-energized. Operating range tests are completed with the product energized, verifying that all main functions operate within tolerance over the defined working temperature range  $-25^{\circ}\text{C}$  to  $+55^{\circ}\text{C}$ .

### **HUMIDITY TEST**

The humidity test is completed to make sure that the product will withstand and correctly function when exposed to 93% relative humidity at a constant temperature of  $40^{\circ}\text{C}$  for 56 days. Tests are completed to make sure that the product operates correctly within specification after 21 and 56 days. After the test, visual verifications are done for any signs of unacceptable corrosion.

### **CYCLIC TEMPERATURE/HUMIDITY TEST**

This is a short-term test that stresses the protection relay by exposing it to temperature cycling in conjunction with high humidity. The test does not replace the 56 day humidity test, but is used for testing extension to ranges or minor modifications to show that the design is unaffected. The applicable standard is IEC60068-2-30 and test conditions are:

- 95% relative humidity are used, over the 24 hour cycle shown in Figure 9.
- $+25^{\circ}\text{C}$   $-3^{\circ}\text{C}$  and 95% relative humidity/ $+55^{\circ}\text{C}$   $-2^{\circ}\text{C}$

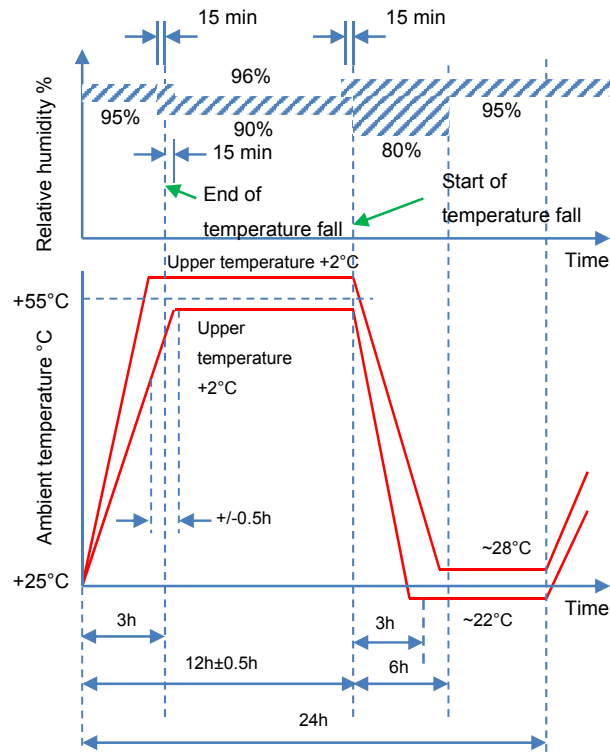

Figure 9. Cyclic temperature/humidity test profile

For these tests the protection relay is put in a humidity cabinet, and energized with typical in-service quantities for the complete duration of the tests. This typically means energizing the protection relay with currents and voltages such that it is 10% from the operation threshold. Throughout the test duration the protection relay is controlled to make sure that no unwanted operations happen. Once the protection relay is removed from the humidity cabinet, its insulation resistance is measured to make sure that it has not deteriorated below the specified level. The protection relay is then functionally checked again, and finally dismantled to verify for signs of component corrosion and growth. The acceptance criterion is that no unwanted operations shall happen including transient operation of indicating devices. After the test the protection relay's insulation resistance should not have decreased, and it should complete all of its main protection and communications functions within the specified tolerance. The protection relay should also suffer no significant corrosion or growth, and photographs are typically taken of each PCB.

## **ENCLOSURE PROTECTION TEST**

Enclosure protection tests verify if the casing system and connectors on the product protect against the ingress of dust, moisture, water droplets and other pollutants. An 'acceptable' level of dust or water may enter the case during testing, but must not affect normal product operation, safety or cause tracking across connector insulated parts.

## **MECHANICAL TESTS**

Mechanical tests model a number of various mechanical circumstances that the product may have to withstand during its lifetime. These fall into two groups:

- disturbances response while energized
- disturbances response during transportation (deenergized state)

Tests in the first category are related with the vibration response, shock and seismic disturbance. The tests model typical in-service conditions for the product. These tests are completed in all three axes, with the product energized in its normal (quiescent) state. During the test, all output contacts are supervised for change using contact follower circuits. Vibration levels of 1g, over a 10Hz-150Hz frequency sweep are applied. Seismic tests use excitation in a single axis, using a 35Hz test frequency and peak displacements of 7.5mm and 3.5mm in the x and y axes respectively below the crossover frequency.

The second category comprises vibration endurance, shock withstand and bump tests. They model the longer-term shock effects and vibration that could happen during transportation. These tests are completed with the product de-energized. After these tests, the product must still function within its specification and show no signs of permanent mechanical damage. Waveform for the shock/bump test is presented in Figure 10.

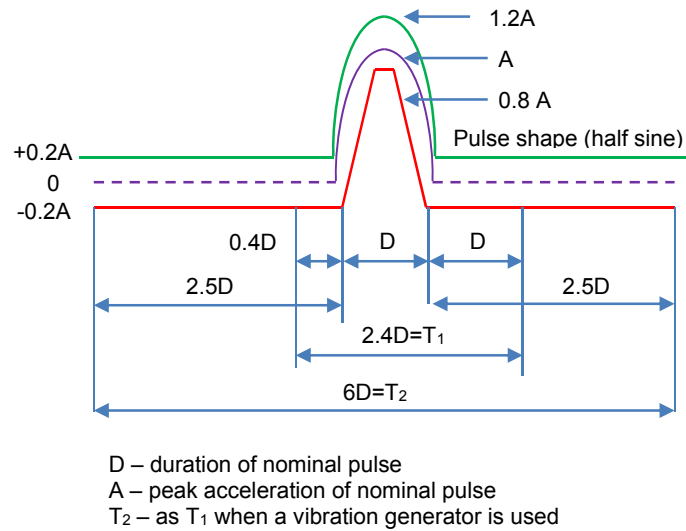

Figure 10. Shock/Bump impulse waveform

The test levels for shock and bump tests are:

Bump (de-energized):

- 1000 pulses, 10g, 16ms duration
- Shock withstand (de-energized):
- 3 pulses, 15g, 11ms duration

Shock response (energized):

- 3 pulses, each 10g, 11ms duration

## SOFTWARE TYPE TESTS

Digital and numerical protection relays use software for relay protection and measurement functions. This software must be properly tested to make sure that the protection relay follows all specifications and that different disturbances do not end in unexpected results. Software is assessed in different stages:

- integration testing
- unit testing
- functional qualification testing

The objective of unit testing is to understand if an individual function or procedure used in the software is free of data, logic, or standards errors. It is easier to discover these



types of errors in individual devices or small groups of devices than it is in an integrated software architecture and/or system. Unit testing is commonly completed against the software detailed design and by the developer of the unit(s). Integration testing commonly focuses on these interfaces and also issues such as performance, timings and synchronization that are not applicable in unit testing. Integration testing also concentrates on 'stressing' the software and related interfaces. Integration testing is 'black box' in nature. It does not consider the structure of individual devices. It is commonly completed against the software architectural and detailed design. The unit developer typically completes the tests, unless high-integrity and/or safety software is used. The specified software demands would commonly be used as a source for some of the test cases.

### **STATIC UNIT TESTING**

Static unit testing evaluates the unit(s) source code for complexity, precision tracking, value tracking, strong type verification, macro analysis etc. While static unit testing can be manually completed, it is a difficult and error prone process and is best done using an automated static unit assessment tool. It is crucial to ensure that any such tool is correctly assembled and used consistently during development.

### **DYNAMIC TESTING**

Dynamic testing is related with the runtime behavior of the checked unit(s). Dynamic unit testing can be sub-divided into 'black box' testing and 'white box' testing. 'Black box' testing checks the implementation of the requirement(s) appointed to the unit(s). It takes no account of the internal structure of the tested unit(s). It is only interested in giving known inputs and checking if the outputs from the unit(s) are correct for those inputs. 'White box' testing is interested with unit(s) internal structure testing and measuring the test coverage. For example, the goal of the unit testing may be to reach 100% statement coverage, in which every line of the code is completed at least once.

### **UNIT TESTING ENVIRONMENT**

Both dynamic and static unit testing are completed in the host environment rather than the target environment. Dynamic unit testing uses a test harness to complete the concerned unit(s). The test harness is made such that it models the interfaces of the

tested unit(s) – both software-software interfaces and software-hardware interfaces. The test harness gives the test data to tested units and outputs the test results in a form understandable to a developer. There are many testing tools to automate test harness production and test execution.

### **SOFTWARE/SOFTWARE INTEGRATION TESTING**

Software/software integration testing is done in the host environment. It applies a test harness to model inputs and outputs, hardware calls and system calls.

### **SOFTWARE/HARDWARE INTEGRATION TESTING**

Software/hardware integration testing is completed in the target environment, i.e. it applies the actual target hardware, operating system, drivers etc. It is typically completed after software/software integration testing. Testing the interfaces to the hardware is crucial feature of software/hardware integration testing. Test cases for integration testing are usually based on those defined for validation testing. Nevertheless, the focus should be on spotting errors and problems. Completing a dry run of the validation testing usually completes integration testing.

### **VALIDATION TESTING**

The purpose of validation testing (also known as software acceptance testing) is to check that the software meets its defined functional requirements. Validation testing is completed against the software requirements, using the target environment. In ideal conditions, someone independent of the software development completes the tests. In the case of high-integrity and/or safety critical software, this independence is crucial. Validation testing is 'black box' in nature. It does not consider the internal software structure. For protection relays, the non-protection functions included in the software are regarded as important as the protection functions. Therefore, they are tested in the same manner. Each validation test should have predefined evaluation criteria that can be used to decide if the test has passed or failed. The assessment criteria should be explicit with no room for interpretation or ambiguity.

## **TRACEABILITY OF VALIDATION TESTS**

Traceability of validation tests to software requirements is crucial. Each software demand documented in the software specification should have at least one validation test.

## **SOFTWARE MODIFICATIONS - REGRESSION TESTING**

Regression testing is not a type test in its' own right. It is the overall name for the testing done when an existing software product is modified. The objective of regression testing is to demonstrate that unintended modifications to the functionality have not been made. Each modification to an existing software product must be studied in its' own right. It is impossible to determine a typical set of regression tests that can be used as a 'catch-all' for introduced errors and defects. Each modification to the software must be assessed to check what risk there might be of unintentional modifications. Those areas of greatest risk will need to be regression examined. Regression testing is very important. If it is not done, there is a great risk of errors being found in the field. Completing it will not decrease the possibility of an error to zero but it will reduce it. Determining the regression testing that is needed is made much easier if there is traceability from adequately documented software requirements through design, coding and testing.

## **DYNAMIC VALIDATION TYPE TESTING**

There are two methods of dynamically demonstrating an adequate performance of protection relays or configurations. The first method is by typically applying faults on the power system and the second is to conduct complex testing on a power system simulator. The former approach is extremely unlikely to be used – lead times are lengthy and the risk of damage makes the tests very expensive. Therefore, it is only used on a very limited basis and the applied faults are fixed in number and type. Because of this, a proving period for new protection device under service conditions has typically been demanded. As faults may happen on the power system at infrequent intervals, it can take a number of years before any shortcomings are found, during which time additional installations may have happened.

Power system simulators can be split into two groups:

- those which use analogue power system techniques
- those which mathematically simulate the power system using digital simulation methods

### **APPLICATION OF POWER SYSTEM ANALOGUE MODELS**

For many years, protection relays have been tested on analogue power system models such as artificial overhead lines, or test plant capable of providing significant currents. Nevertheless, these models have substantial limitations in the current and voltage waveforms that can be produced. Also they are not suitable for automated, unattended, testing programs. While still applied on a limited basis for electromechanical and static relay testing, a fundamentally different approach is needed for dynamic numerical relay testing.

### **APPLICATION OF MICROPROCESSOR BASED SIMULATION DEVICES**

The numerical relay complexity, reliant on implementation software for the included functions, dictates some kind of automated test equipment. Even a testing of simple numerical overcurrent relay functions (including all auxiliary functions) can take few months of automated, 24 hours/day testing. If such test device was able to apply realistic current and voltage waveforms that match those encountered on power systems during fault conditions, the equipment can be used either for type testing of individual relay designs. With this in mind, a new generation of power system simulators has been made. It is capable of giving a far more accurate power system simulation than has been possible in the past. The simulator enables protection relays to be examined under a wide range of system conditions.

### **SIMULATION HARDWARE**

Equipment can now provide high-speed, highly precise power system modeling. The equipment is based on distributed digital hardware under the control of real time software models. Typical equipment is presented in Figure 11. The modules have outputs connected to current and voltage sources that have a similar transient capability and have adequate output levels for direct connection to the protection relay inputs. Inputs are also provided to supervise the protection relay response (contact

closures for tripping, etc.) and these inputs can be used as part of the power system model. The software can also accurately model the dynamic response of CTs and VTs. The digital simulator can also be digitally linked to the protection relay(s).



Figure 11. Digital power system simulator for relay/protection configuration testing

This approach introduces many benefits over traditional test devices:

- the power system model is capable of reproducing high frequency transients such as travelling waves
- saturation effects in CTs and VTs can be simulated
- it is not impacted by the harmonic content, noise and frequency changes in the AC supply
- tests involving very long time constants can be completed
- a set of test routines can be defined in software and then left to run unattended (or with only frequent supervision) to completion, with a comprehensive record of test results
- it is capable of representing the change in the current related with generator faults and power swings
- the IEC61850 interface capabilities allow protection relays intended for applications in digital substations to be examined.

A block diagram of the equipment is presented in Figure 12. It is based around a computer which computes and stores the digital information representing the system voltages and currents. The computer controls conversion of the digital information into analogue signals, and it supervises and controls the protection relays.

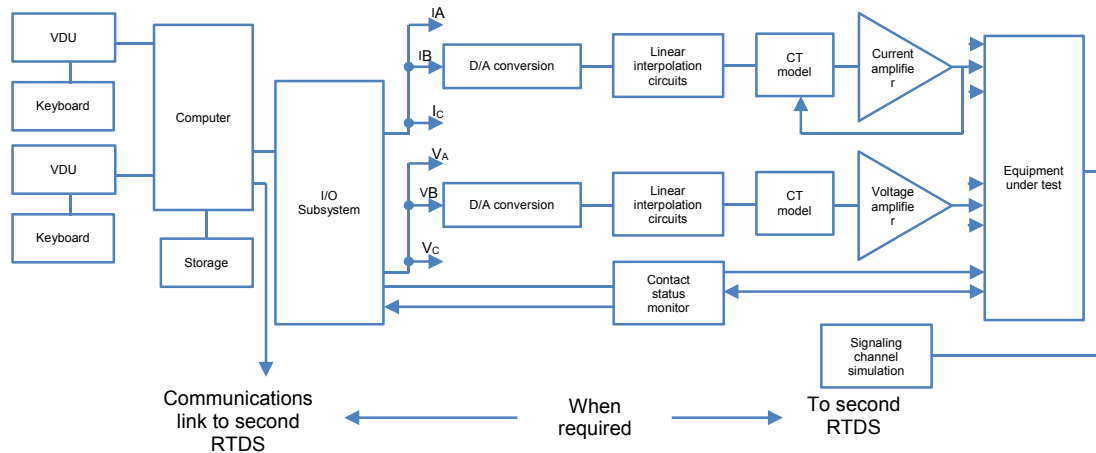

Figure 12. Block diagram of real-time digital protection relay test arrangement

## SIMULATION SOFTWARE

Unlike most conventional software used for power systems assessment, the used software is suitable for the fast transients modeling. These transients happen in the first few milliseconds after fault inception. Two very precise simulation programs are applied, one based on time domain and the other on frequency domain methods. In both programs, single and double circuit transmission lines are modeled by fully distributed parameter models. The transmission line parameters are computed from the physical construction of the line, taking into consideration the effect of conductor geometry, conductor internal impedance and the ground return path. It also includes the line parameter frequency dependence in the frequency domain program. The frequency dependent variable effects are computed using Fast Fourier Transforms. Obtained results are converted to the time domain. Conventional current transformers and capacitor voltage transformers can be modeled. The fault can be applied at any system point and can be any combination of line to line or line to ground, resistive, or non-linear phase to ground arcing faults. For series compensated transmission lines, flashover across a series capacitor following a short circuit fault can be modeled. The frequency domain model is not adequate for developing faults and switching

sequences. Hence, the widely used Electromagnetic Transient Program (EMTP), working in the time domain, is used in such situations. In addition to these two programs, a simulation program based on lumped resistance and inductance parameters is used. This simulation is used to model systems with long time constants and slow system changes such as power swings.

## **SIMULATOR APPLICATIONS**

The simulator is used for verifying the calibration accuracy and completing type tests on a wide range of protection relays during their development. It has the following benefits over existing test methods:

- 'state of the art' power system modeling information can be used to test protection relays
- freedom from frequency changes and noise or harmonic content of the laboratory's own domestic supply
- chosen harmonics may be laid over the power frequency
- all tests are precisely repeatable
- the protection relay under test does not burden the power system
- wide bandwidth signals can be generated
- a wide range of frequencies can be reproduced
- reproduces fault currents whose peak amplitude changes with time
- transducer models can be included
- two such devices can be linked together to model a system with two relaying points
- the use of direct coupled current amplifiers allows time constants of any length
- capable of simulating slow system changes
- automatic testing removes the likelihood of measurement and setting errors

The simulator is also used for the relay production testing, in which most of the benefits mentioned above apply. As the tests and measurements are done automatically, the testing quality is also highly improved. Also, in situations of suspected relay malfunction under known fault conditions, the simulator can be used to replicate the power system and fault conditions, and complete a comprehensive investigation about relay performance. Finally, complex protection configurations can be simulated, using

both the protection relays intended for use and software models as appropriate. Figure 13(a) presents a particular power system section. Figure 13(b) displays the three phase voltages and currents waveforms at the primaries of  $V_{T1}$  and  $C_{T1}$  for the fault condition indicated in Figure 13(a).

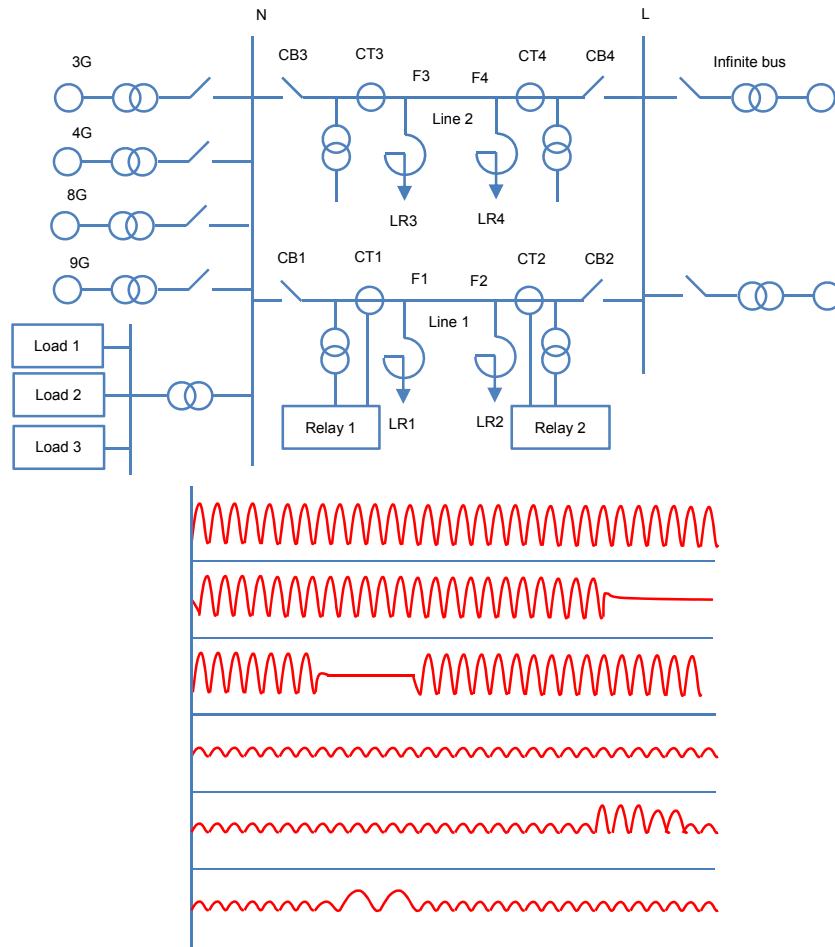

Figure 13. Example of application study (a) Studied power system (b) Voltages and currents at  $V_{T1}/C_{T1}$  power system

## PRODUCTION TESTING

Protection relay production testing is becoming far more challenging as the accuracy and complexity of the products increase. Electronic power amplifiers are applied to supply precise voltages and currents of high stability to the protection relay under test. The inclusion of a computer in the test system allows more comprehensive testing to be done at an economical cost, with the benefit of speed and repeatability. Figure 14 presents a modern computer-controlled test bench. The hardware is placed in a



special rack. Each unit of the test system is linked to the computer via an interface bus. Individual test programs for each type of protection relay are needed, but the interface used is standard for all protection relay types. Control of input waveforms and analogue measurements, the monitoring of output signals and the data assessment are completed by the computer. A printout of the test results can also be made.



Figure 14. Modern computer-controlled test bench

Because software is extensively examined at the type-testing stage, there is typically no need to verify the correct functioning of the software. Verifications are limited to determining that the analogue and digital I/O is operating correctly. This is accomplished for inputs by applying known voltage and current inputs to the protection relay and verifying that the software has taken the correct values. Similarly, digital outputs are exercised by using test software to actuate each output and verifying that the adequate output is energized. Provided that adequate methods are in place to ensure that only type tested software is used, there is no need to verify the correct functioning of the relay software. The final step is to get the software appropriate to the relay and keep it in the protection relay's non-volatile memory.

## **COMMISSIONING TESTS**

Installation of a protection arrangement at site introduces a number of possibilities for errors in the scheme implementation. Even if the protection configuration has been tested in the factory, wiring to the CTs and VTs on site may be incorrectly done, or the CTs/VTs may have been incorrectly installed. The effect of such errors may range from simply being a nuisance tripping through to failure to operate under fault conditions. This can lead to major equipment damage, disruption to supplies and potential hazards to staff. The available strategies to prevent these risks are many, but all involve some kind of testing at site. Hence, commissioning tests at site are invariably completed before protection equipment is set to work. The objectives of commissioning tests are:

- to demonstrate the correct functioning of the protection configuration as a whole
- to make sure that the equipment has not been damaged during transit or installation
- to make sure that the installation work has been correctly completed

The completed tests will typically vary according to the selected protection configuration, the applied protection relay technology, and the policy of the client. In many situations, the conducted tests are determined at the commissioning time by mutual agreement between the client's representative and the commissioning team. Therefore, it is not possible to give a final list of tests that are needed during commissioning. Therefore, this paragraph describes typically completed tests during commissioning. The following tests are invariably completed, since the protection configuration will not correctly work if faults exist.

- overall equipment inspection, checking all connections, wires on protection relays terminals, labels on terminal boards, etc.
- wiring diagram verification, using circuit diagrams presenting all the reference numbers of the interconnecting wiring
- complete relay self-test procedure and external communications verifications on digital/numerical protection relays
- insulation resistance measurement of all circuits
- test main voltage transformers
- test main current transformers

- tripping and alarm circuit checks to demonstrate correct functioning
- verify that protection relay alarm/trip settings have been correctly entered

Also, the following verifications may be completed, depending on the factors noted earlier.

- primary injection tests on each protection relay to demonstrate stability for external faults and to determine the effective current setting for internal faults
- secondary injection test on each protection relay to demonstrate operation at one or more setting values
- testing of protection configuration logic

This section presents the required tests to cover the above items.

## **INSULATION TESTS**

All the deliberate ground connections on the wiring to be tested should first be removed, for example grounding links on current transformers, voltage transformers and DC. supplies. Some insulation testers produce impulses with peak voltages exceeding 5kV. In these situations any electronic equipment should be disconnected while the external wiring insulation is verified. The insulation resistance should be measured to ground and between electrically separate circuits. The readings are recorded and cross compared with next routine tests to check for any insulation deterioration. The measured insulation resistance depends on the amount of wiring, its grade, and the site humidity. Typically, if the test is restricted to one cubicle, a reading of few hundred megohms should be obtained. If long lengths of site wiring are included, the reading could be only a few megohms.

## **PROTECTION RELAY SELF-TEST PROCEDURE**

Digital and numerical protection relays will have a self-test procedure that is presented in the relay manual. These tests should be followed to verify if the protection relay is operating correctly. This will typically involve verification of the protection relay watchdog circuit, exercising all digital inputs and outputs and verifying that the protection relay analogue inputs are within calibration by using a test current or voltage. For these tests, the protection relay outputs are typically disconnected from

the remainder of the protection configuration, since it is a test conducted to prove correct relay. Unit protection configurations involve protection relays that need to communicate with each other. This leads to extra testing requirements. The communications path between the protection relays is tested using adequate equipment to make sure that the path is complete and that the received signal strength is within specification. Numerical protection relays may be equipped with loopback test facilities that enable either part of or the entire communications link to be tested from one end. After test completion, it is common to enter the protection relay settings. This can be completed manually via the relay front panel controls, or using a portable PC and suitable software. Whichever, method is applied verification by a second person that the correct settings have been used is desirable. Programmable configuration logic that is needed is also entered at this stage.

## CURRENT TRANSFORMER TESTS

The following tests are typically completed prior to main circuit energization.

### POLARITY VERIFICATION

Each current transformer should be separately tested to check that the primary and secondary polarity markings are correct as shown in Figure 15. The ammeter linked to the current transformer secondary should be a robust moving coil, permanent magnet, center-zero type. A low voltage battery is installed, via a single-pole push-button switch, to energize the primary winding. On closing the push-button, the DC ammeter, A, should return a positive flick and on opening, a negative flick.

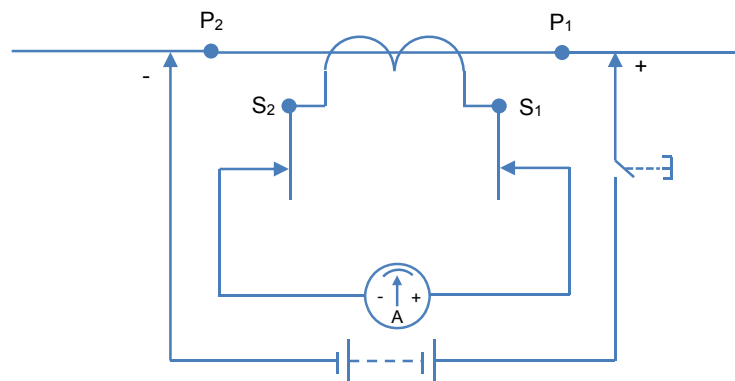

Figure 15. Current transformer polarity verification

## MAGNETIZATION CURVE

Few points should be verified on each current transformer magnetization curve. This can be completed by energizing the secondary winding from the local mains supply through a variable auto-transformer while the primary circuit remains open. This is presented in Figure 16. The characteristic is measured at suitable intervals of applied voltage, until the magnetizing current is detected to rapidly rise for a small increase in voltage. This suggests the current transformer approximate knee-point or saturation flux level. The magnetizing current should then be recorded at similar voltage intervals as it is decreased to zero. Attention has to be taken that the test equipment is properly rated. The short-time current rating must be in excess of the CT secondary current rating, to allow for saturation current measurement. This will be in excess of the CT secondary current rating. As the magnetizing current will not be sinusoidal, a moving iron or dynamometer type ammeter should be used. It is often found that current transformers with secondary ratings of 1A or less have a knee-point voltage higher than the local mains supply. In these situations, a step-up interposing transformer must be installed to get the necessary voltage to verify the magnetization curve.

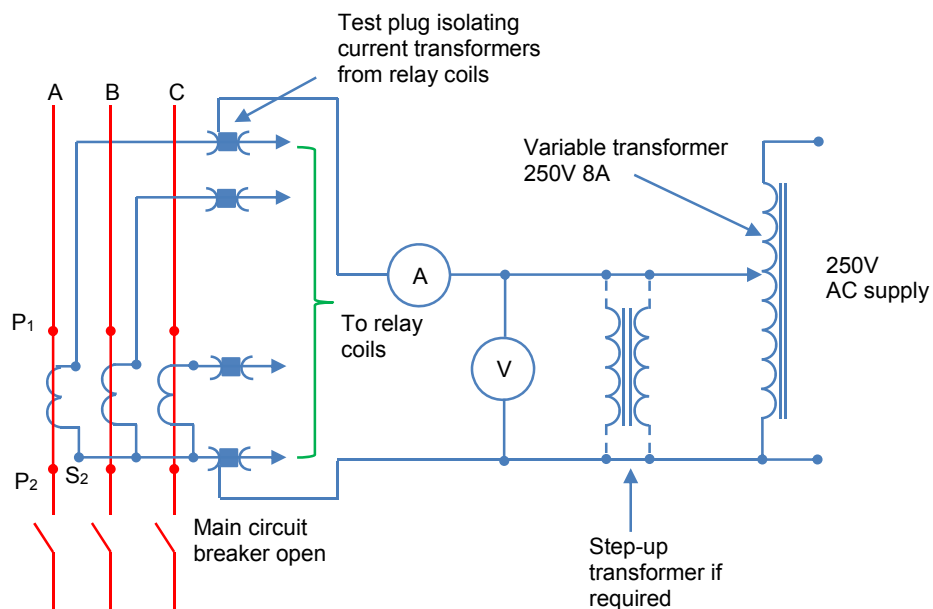

Figure 16. Current transformer magnetizing curve verification

## **VOLTAGE TRANSFORMER TESTS**

Voltage transformers need polarity and phasing testing.

### **POLARITY VERIFICATION**

The voltage transformer polarity can be verified by using the method for CT polarity tests. Attention has to be taken to connect the battery supply to the primary winding, with the polarity ammeter linked to the secondary winding. If the voltage transformer is of the capacitor type, then the transformer polarity at the bottom of the capacitor stack should be verified.

### **RATIO VERIFICATION**

This verification can be completed when the main circuit is first made live. The voltage transformer secondary voltage is cross compared with the secondary voltage entered on the nameplate.

### **PHASING VERIFICATION**

The secondary connections for a three-phase voltage transformer or a bank of three single-phase voltage transformers must be verified for phasing. With the main circuit energized, the phase rotation is verified using a phase rotation meter installed across the three phases, as presented in Figure 17. Provided an existing proven VT is available on the same primary system, and that secondary grounding is used, all that is now necessary to demonstrate correct phasing is a voltage check between, say, both 'A' phase secondary outputs. There should be nominally little or no voltage if the phasing is correct. Nevertheless, this test does not discover if the phase sequence is adequate, but the phases are displaced by 120° from their correct position. For example, phase A occupies the position of phase C or phase B in Figure 17. This can be verified by removing the fuses from phases B and C and measuring the phase-ground voltages on the VT secondary. If the phasing is correct, only phase A should be healthy, phases B and C should have only a small residual voltage.

Adequate phasing should be further substantiated when completing 'on load' tests on any phase-angle sensitive protection relays, at the relay terminals. Load current in a

known phase CT secondary should be cross compared with the related phase to neutral VT secondary voltage. The phase angle between them should be measured, and should relate to the system load power factor. If the three-phase voltage transformer has a broken-delta tertiary winding, then a verification should be made of the voltage across the two connections from the broken delta VN and VL, as presented in Figure 17. With the rated balanced three phase supply voltage applied to the voltage transformer primary windings, the broken-delta voltage should be below 5V with the connected rated burden.

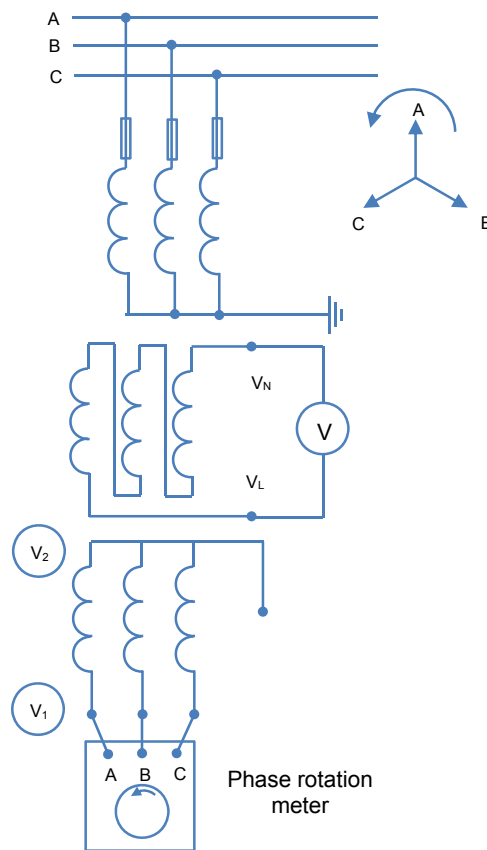

Figure 17. Voltage transformer phasing verification

## PROTECTION RELAY SETTING VERIFICATIONS

At some point during commissioning, the alarm and trip settings of the protection relay elements will need to be entered and/or checked. Where the complete configuration is designed and supplied by a single contractor, the settings may already have been

entered prior to dispatch from the factory. Therefore, this does not have to be repeated. The settings entering method varies according to the used relay technology. For electromechanical and static protection relays, manual entry for each protection relay element is needed. This method can also be applied for digital/numerical protection relays. Nevertheless, the amount of information to be entered is much higher. Hence, it is common to use adequate software, typically provided by the manufacturer. The software also makes the basic task of making a record of the data entered much easier. Once the data has been entered, it should be verified for compliance with the suggested settings as calculated from the protection setting study. Where adequate software is used for data entry, the verifications can be considered complete if the information is checked prior to download of the settings to the relay. Otherwise, additional verification may be needed. The recorded commissioning settings have to be provided to the client.

## **SECONDARY INJECTION TEST DEVICES**

Secondary injection tests are normally completed prior to primary injection tests. The objective of secondary injection testing is to demonstrate the correct operation of the protection configuration that is downstream from the protection relay(s) inputs. Secondary injection tests are done before primary injection tests. This is done because the risks during initial equipment LV side testing are minimized. The primary (HV) side of the equipment is disconnected, so that no damage can happen. These tests and the necessary equipment to complete them are typically described in the manufacturer's protection relay manuals.

## **TEST BLOCKS/PLUGS FOR SECONDARY INJECTION DEVICES**

It is typical practice to supply test blocks or test sockets in the protection relay circuits so that connections can be made to the test equipment without disturbing wiring. Test plugs of either multi-finger or single-finger configuration (for current monitoring in one CT secondary circuit) are applied to connect test devices to the protection relay under test. The top and bottom contact of each test plug finger is split by an insulating strip, so that the protection relay circuits can be totally isolated from the switchgear wiring when the test plug is installed. To avoid open-circuiting CT secondary terminals, it is essential that CT shorting jumper links are fitted across all appropriate 'live-side'



terminals of the test plug before it is inserted. With the test plug placed in position, all the test circuitry can now be linked to the isolated 'relay side' test plug terminals. Some modern test blocks contain the live-side jumper links within the block. These can be appropriately set to the 'closed' or 'open' position, either manually prior to removing the cover and inserting the test plug, or automatically upon cover removal. Cover removal also exposes the color-coded face-plate of the block, clearly showing that the protection configuration is not in service, and may also disconnect any DC auxiliary supplies used for powering protection relay tripping outputs. Removing the test plug instantly restores the main current transformers and voltage transformers connections and removes the test connections. Replacement of the test block cover then removes the short circuits that had been applied to the main CT secondary circuits. Where few protection relays are used in a protection configuration, one or more test blocks may be installed on the relay panel enabling the whole configuration to be tested, rather than just one protection relay at a time. Test blocks typically provide facilities for the monitoring and secondary injection testing of any power system protection configuration. The test block may be used either with a multi fingered test plug to allow isolation and monitoring of all selected conductor paths, or with a single finger test plug that allows the currents on individual conductors to be monitored. A modern test block and test plugs are presented in Figure 18.



Figure 18. Modern test block

## **SECONDARY INJECTION TEST SETS**

The protection relay type to be examined determines the equipment type used to supply the secondary injection currents and voltages. Many electromechanical protection relays have nonlinear current coil impedance when the protection relay works and this can cause the test current waveform to be distorted if the injection supply voltage is directly supplied to the coil. The harmonics presence in the current waveform may impact the torque of electromechanical protection relays and provide unreliable test results, so some injection test sets use an adjustable series reactance to control the current. This keeps the power dissipation small and the equipment light and compact. Many test devices are easily portable and include precision ammeters and voltmeters and timing equipment. Test devices may have both voltage and current outputs. The former are high voltage, low current outputs for use with protection relay elements that need signal inputs from a VT as well as a CT. The current outputs are high-current, low voltage to connect to protection relay CT inputs. Nevertheless, it is important to make sure that the test set current outputs are true current sources. Therefore, they are not affected by the load impedance of a protection relay element current coil. Application of a test set with a current output that is basically a voltage source can introduce serious problems when testing electromechanical protection relays. Any major impedance mismatch between the output of the test set and the protection relay current coil during relay operation will introduce a current variation from that desired and potential error in the test results. The protection relay operation time may be higher than expected (never less than expected) or relay 'chatter' may happen. It is quite typical for such errors to be detected later, after a fault has caused significant damage to equipment through failure of the primary protection. Failure investigation then indicates that the reason for the primary protection operation is an incorrectly set protection relay. Figure 19 presents common waveforms resulting from application of test set current output that is a voltage source. The distorted protection relay coil current waveform introduces an extended operation time compared to the expected value.

Modern test sets are computer based. They use a standard PC and a power amplifier that takes the PC low-level outputs and amplifies them into voltage and current signals adequate for application to the protection relay VT and CT inputs. The phase angle

between voltage and current outputs will be adjustable, as also will the phase angles between the individual voltages or currents making up a 3-phase output set. Much higher precision in the magnitude and phase angle settings is possible in comparison with traditional test sets. Digital signals to exercise the protection relay internal logic may also be provided. The protection relay alarm and trip outputs are connected to PC digital inputs so that correct relay operation, including accuracy of the relay tripping characteristic can be monitored and displayed on-screen, saved for inclusion in reports, or printed for an immediate presentation. Extra features may include GPS time synchronising elements and remote installed amplifiers to facilitate unit protection configuration testing, and digital I/O for exercising the programmable configuration logic of modern protection relays.

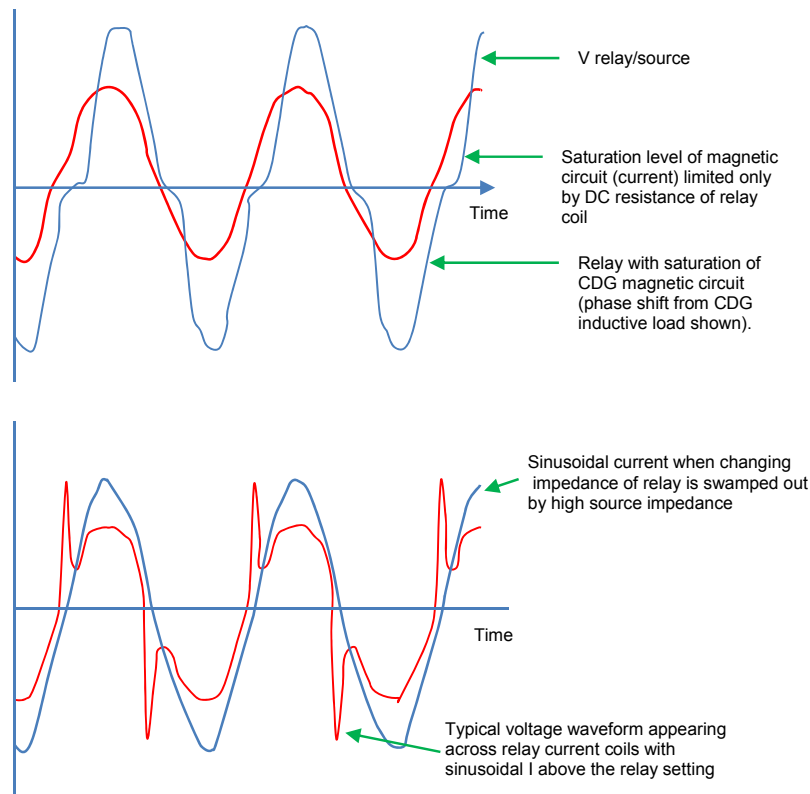

Figure 19. Protection relay current coil waveforms (a) Protection relay current coil waveform distorted due to use of voltage source (b) Undistorted protection relay current coil current distorted due to use of current source

Some test sets provide a digital interface for IEC61850 GOOSE I/O supervision and for virtual "injection" of IEC 61850-9-2 sampled values. The software for modern test

sets is capable of testing the functionality of a wide range of protection relays, and automatically completing a set of tests. Such sets ease commissioning engineer tasks. The software will typically provide options for testing, ranging from a test completed at characteristic particular point to complete and automatic determination of the tripping characteristic. This option can be useful if there is any reason to doubt that the protection relay is functioning correctly with the specified tripping characteristic. Figure 20 presents a modern PC-based test set. Traditional test sets use an adjustable transformer arrangement and reactors to give current and voltage control without incurring high power dissipation. Some protection relays require adjustment of the phase between the injected voltages and currents. Therefore, phase shifting transformers may be used.



Figure 20. Modern PC-based secondary injection test equipment

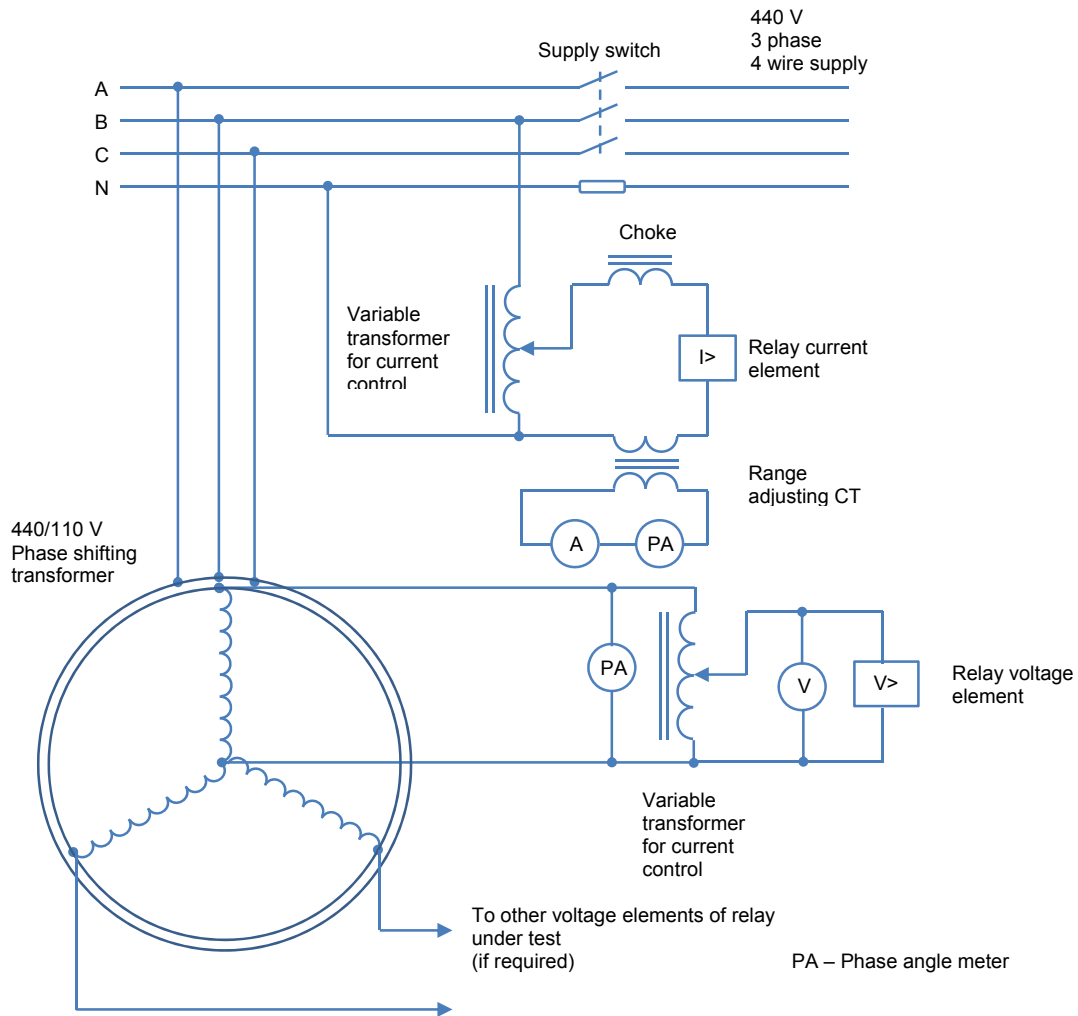

Figure 21. Circuit diagram for traditional test set for directional/distance relays

## SECONDARY INJECTION TESTING

The objective of secondary injection testing is to verify that the protection configuration from the protection relay input terminals onwards is operating correctly with the specified settings. This is accomplished by using suitable inputs from a test set to the inputs of the protection relays and verifying if the appropriate alarm/trip signals occur at the relay/control room/CB locations. The testing extent will be highly determined by the client specification and used protection relay technology, and may range from a simple verification of the protection relay characteristic at a single point to a complete tripping characteristic check. This includes the response to transient waveforms and harmonics and relay bias characteristic verification. This may be crucial when the

protection configuration includes transformers and/or generators. The testing should include any configuration logic. If the logic is implemented using the programmable configuration logic facilities available with most digital or numerical protection relays, adequate digital inputs may need to be applied and outputs monitored. It is evident that a modern test set can allow such tests, leading to a reduced testing time.

### **CONFIGURATIONS USING DIGITAL OR NUMERICAL RELAY TECHNOLOGY**

The policy for secondary injection testing widely differs. In some situations, manufacturers suggest, and clients accept, that if a digital or numerical protection relay passes its' self-test, it can be relied upon to function at the used settings. Therefore that testing can be confined to those parts of the configuration external to the protection relay. In such situations, secondary injection testing is not needed. More frequently, it is needed that one element of each protection relay is exercised, using a secondary injection test set, to verify that protection relay operation happens at the expected conditions, based on the setting of the analyzed relay element. Another option is to assess the relay overall functionality. This is rarely needed with a digital or numerical protection relay, probably only being done in the case of a suspected relay malfunction. To demonstrate the results that can be obtained, Figure 22 presents the results obtained by a modern test set when determining the reach settings of a distance relay using a search technique.

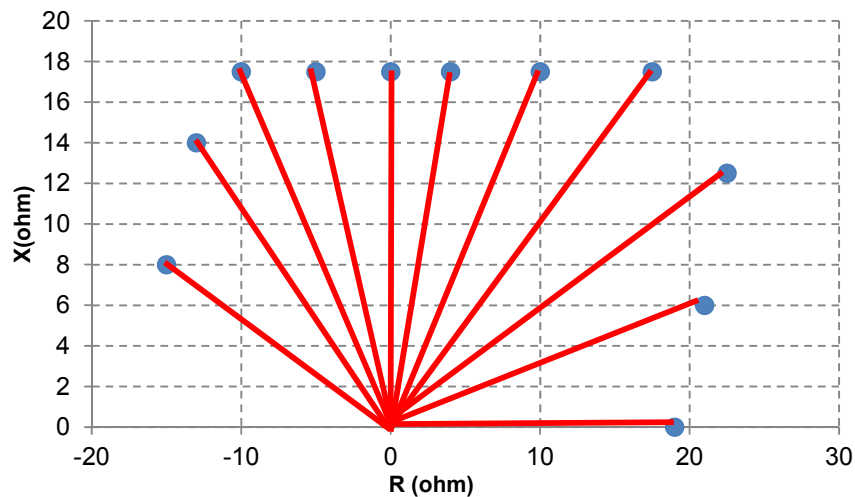

Figure 22. Distance protection relay zone checking using search technique and tolerance bands (Fault A-N)

## **CONFIGURATIONS USING ELECTROMECHANICAL/STATIC PROTECTION RELAY TECHNOLOGY**

Configurations using single function electromechanical or static protection relays will typically need assessment of each relay. Therefore, a configuration with distance and back-up overcurrent elements will demand a test on each of these functions. Eventually, this will need more time than if a digital or numerical protection relay is used. Similarly, it may be important to verify the protection relay characteristic over a range of input currents to confirm parameters for an overcurrent protection relay such as:

- the maximum current at which resetting happens
- the minimum current that gives operation at each current setting
- the resetting time at zero current with the TMS at 1
- the time/current curve at two or three points with the time multiplier setting TMS at 1
- the operating time at suitable values of current

## **TEST CIRCUITS FOR SECONDARY INJECTION TESTING**

The used test circuits will depend on the relay type and used test set. Unless the test circuits are simple and obvious, the protection relay commissioning manual will provide circuit details. When using the circuits in this reference, appropriate simplifications can easily be made if digital or numerical protection relays are being tested.

All results should be recorded. Deviations from the expected results must be thoroughly checked and the cause discovered. After rectification of errors, all tests whose results may have been affected (even those that may have given correct results) should be repeated to make sure that the protection configuration has been implemented in line with the specifications.

## **PRIMARY INJECTION TESTS**

This test type includes the entire circuit; current transformer primary and secondary windings, protection relay coils, trip and alarm circuits, and all intervening wiring are verified. There is no need to disturb wiring, which eliminates the hazard of open-

circuiting current transformers, and there is typically no need for any switching in the current transformer or protection relay circuits. The disadvantage of such tests is that they are time consuming and expensive. Also, reliance is placed on all wiring and installation diagrams being correct and the installation being completed as per drawings, and secondary injection testing being satisfactorily carried out. Under these conditions, the primary injection tests may be excluded. Nevertheless, wiring errors between VTs/CTs and protection relays, or VTs/CTs incorrect polarity may not then be discovered until either spurious tripping happens, or more seriously, failure to trip on a fault. This hazard is much decreased where digital/numerical protection relays are installed, since the current and voltage measurement/display facilities that exist in such protection relays enable checking of protection relay input values against those from other proven sources. Many connection/wiring errors can be detected in this way. Also by temporarily isolating the protection relay trip outputs, unwanted trips can be averted. Nevertheless, primary injection testing is the only way to demonstrate correct installation and operation of the complete protection configuration. As noted in the previous section, primary injection tests are always completed after secondary injection tests, to make sure that problems are limited to the involved VTs and CTs, plus associated wiring. All other equipment in the protection configuration should have proven satisfactory operation during secondary injection tests.

## **TEST FACILITIES**

An alternator is the most useful source of power for providing the heavy current necessary for primary injection. However, it is rarely available, since it demands not only a spare alternator, but also spare busbars capable of being linked to the alternator and circuit under test. Hence, primary injection is typically completed by means of a portable injection transformer (Figure 23), made to function from the local mains supply and having several low voltage, heavy current windings. These can be connected in series or parallel according to the needed current and the primary circuit resistance. Outputs of 10V and 1000A can be achieved. Optionally, modern PC-controlled test sets have power amplifiers able to inject currents up to about 200A for a single unit, with higher current ratings being possible by using multiple units in parallel.



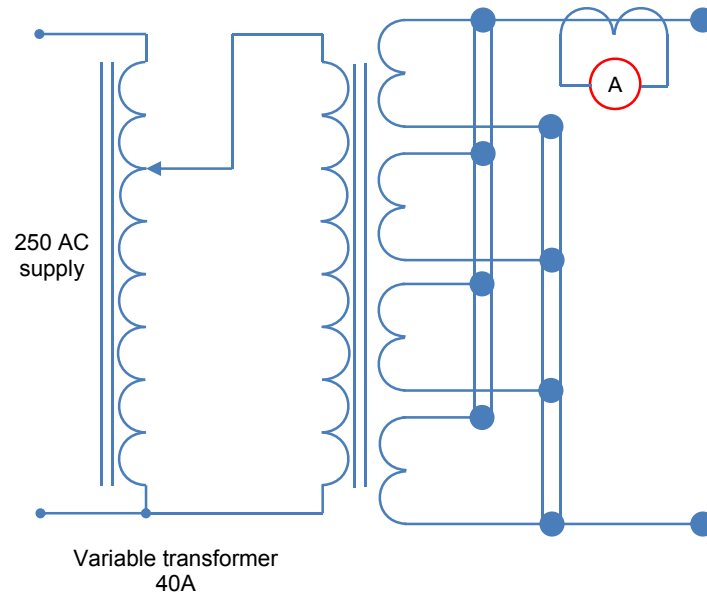

Figure 23. Common primary injection test set

If the main current transformers are fitted with test windings, these can be used for primary injection instead of the primary winding. The current needed for primary injection is then highly decreased and can typically be obtained using secondary injection test equipment. However, test windings are not typically provided, because of space limitations in the main current transformer housings or the windings cost.

### CT RATIO CHECK

Current is transferred through the primary conductors and measured on the test set ammeter,  $A_1$  as presented in Figure 24. The secondary current is measured on the ammeter  $A_2$  or protection relay display, and the ratio of the value on  $A_1$  to that on  $A_2$  should closely approximate to the ratio marked on the current transformer nameplate.

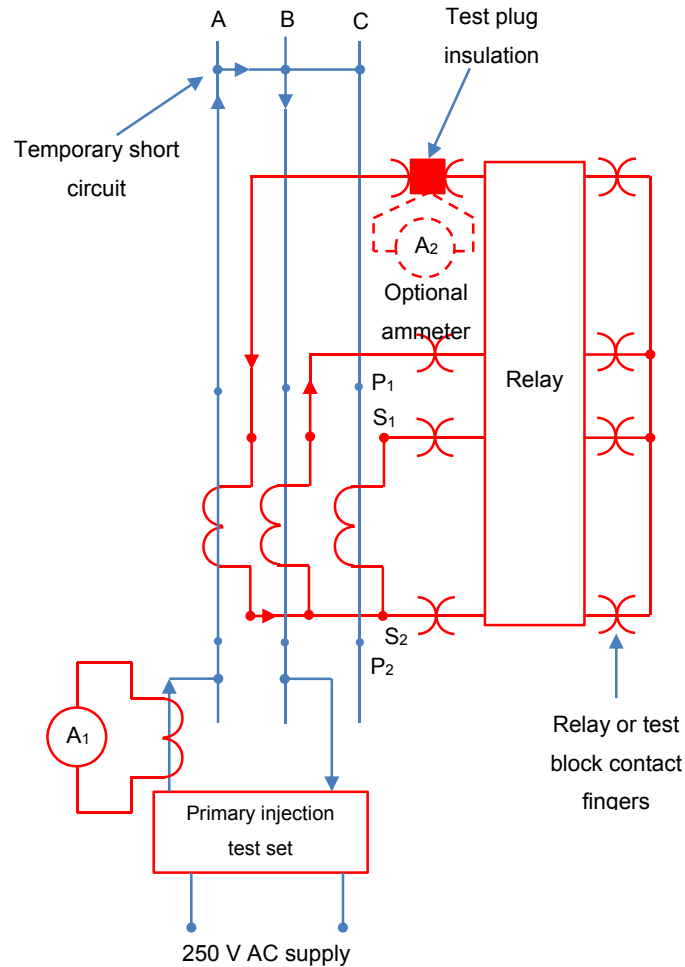

Figure 24. Current transformer ratio verification

### CT POLARITY VERIFICATION

If the equipment involves directional, differential or ground fault protection relays, the main current transformer polarity must be verified. It is not mandatory to complete the test if only overcurrent protection relays are used. The circuit for verifying the polarity with a single-phase test set is presented in Figure 25. A short circuit is placed across the primary circuit phases on one side of the current transformers while single-phase injection is completed on the other side. The ammeter installed in the residual circuit, or protection relay display, will provide a reading of a few milliamperes with rated current injected if the current transformers are of correct polarity. A reading proportional to twice the primary current will be got if they are of wrong polarity. Because of this, a high-range ammeter should be initially applied, for example one

giving complete-scale deflection for twice the rated secondary current. If an electromechanical ground-fault protection relay with a low setting is also installed in the residual circuit, it is suggested to temporarily short-circuit its operating coil during the test. This is done to prevent possible overheating. The single-phase injection should be completed for each pair of phases.

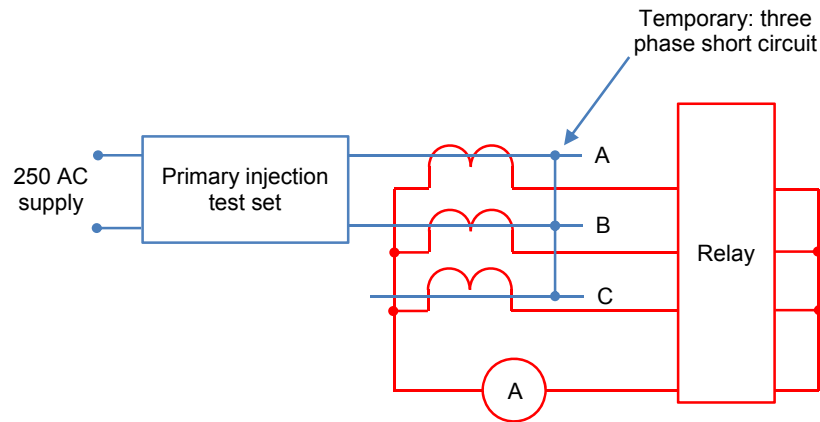

Figure 25. Polarity verification on main current transformers

## PRIMARY INJECTION TESTING OF PROTECTION RELAY ELEMENTS

The tests to be completed will be those defined by the client, and/or those detailed in the protection relay commissioning manual. Digital and numerical protection relays typically need fewer tests to demonstrate correct operation, and these may be limited to observations of current and voltage on the protection relay display under normal load conditions.

## TESTING OF PROTECTION CONFIGURATION LOGIC

Protection configuration typically involves the use of logic to check the conditions under which designated circuit breakers should be tripped. Traditionally, this logic was used by means of discrete relays, separate from the relays used for protection. Such installations would happen where electromechanical or static relay technology is used. Nevertheless, digital and numerical protection relays typically include programmable logic as part of the software within the relay, together with related digital I/O. This facility (usually referred to as Programmable Scheme Logic, or PSL) provides important benefits to the user, by saving space and allowing modifications to the

protection configuration logic through software if the protection configuration requirements change with time. Modifications to the logic are completed using software installed on a PC and downloaded to the relay. Use of programming languages specified in IEC 61131, such as ladder logic or Boolean algebra is typical for such software, and is clearly understood by protection engineers. Also, there are several typically encountered protection functions that manufacturers may provide with relays as one or more 'default' logic schemes. Because software is used, it is important to carefully test the logic during commissioning to ensure adequate operation. The only exception to this may be if the adequate 'default' configuration is used. Such logic configurations have been proven during relay type testing. Therefore, there is no need for proving tests during commissioning. Nevertheless, where a customer develops the scheme logic, it is necessary to make sure that the completed commissioning tests are adequate to demonstrate the configuration functionality. A particular test process should be made, and this procedure should include:

- scheme logic specification and diagram verification to make sure that the logic objectives are accomplished
- logic testing to make sure that the configuration functionality is demonstrated
- logic testing, as needed, to make sure that no output happens for the relevant input signal combinations

The degree of logic testing is highly dependent on the criticality of the application and the logic complexity. The responsibility for ensuring that a proper test procedure for logic configuration is made lies with the logic author. It cannot be expected that relay manufacturers take responsibility for the correct operation of logic schemes that they have not designed and supplied.

### **TRIPPING AND ALARM ANNUNCIATION TESTS**

If primary and/or secondary injection tests are not completed the tripping and alarm circuits have not been checked. Even where such verifications have been completed, CB trip coils and/or Control Room alarm circuits may have been isolated. In such situations, it is essential that all of the tripping and alarm circuits are verified. This is accomplished by manually closing the protection relay contacts and verifying that:

- the right flag indications are given

- the alarm circuits are energized
- the right circuit breakers are tripped
- there is no maloperation of other devices that may be connected to the same master trip relay or circuit breaker

Many withdrawable circuit breaker types can be operated while in the maintenance position, so that substation operation can continue unaffected except for the circuit controlled by the selected, withdrawable circuit breaker. In other situations, isolators can be used to avoid the need for busbar de-energization if the selected circuit is not ready for energization.

### **PERIODIC MAINTENANCE TESTS**

Periodic testing is necessary to make sure that a protection configuration continues to give satisfactory performance for many years after installation. All devices are subject to gradual degradation with time, and regular testing is meant to identify the concerned equipment so that remedial action can be completed before configuration maloperation happens. Nevertheless, due care should be taken in this task otherwise faults may be brought in as a direct result of the remedial work. The fault clearance is correct only if the number of circuit breakers opened is the minimum necessary to clear the fault. A small proportion of faults are incorrectly removed, the main reasons being:

- limitations in protection scheme configuration
- incorrect connections
- incorrect settings
- known application shortcomings accepted as improbable occurrences
- faulty protection relays
- defects in the secondary wiring
- switching errors, testing errors, and relay operation due to mechanical shock
- pilot wire faults due to previous unrevealed damage to a pilot cable

The self-checking features of numerical relays assist in minimizing failures due to faulty protection relays. Defects in secondary wiring and incorrect connections are almost eliminated if proper commissioning after configuration installation/alteration is completed. The possibility of incorrect settings is minimized by regular relay setting

reviews. Network fault levels change over time and therefore setting calculations may need to be revised. Switching and testing errors are minimized by proper staff training, use of adequate software, and well-designed systematic working processes. All of these can be said to be within the user control.

## **FREQUENCY OF INSPECTION AND TESTING**

Even though protection equipment should be in good condition when first put into service, problems can develop because of its occasional operation. With digital and numerical protection relays, the in-built self-testing processes can be expected to reveal and annunciate most faults. However, this does not cover any other components that make up the protection configuration. Frequent inspection and testing of a protection configuration is needed. In reality, the testing frequency may be limited by lack of staff or by the power system operating conditions. It is desirable to complete maintenance on protection equipment at times when the associated power devices are out of service. This is facilitated by co-operation between the maintenance staff concerned and the network operations control center. Maintenance tests have to be completed when the protected circuit is loaded. The particular device to be tested should be taken out of service and proper back-up protection provided for the test duration. Such back-up protection may not be totally discriminative, but should be sufficient to remove any fault on the equipment whose main protection is temporarily out of service. Maintenance is assisted by the displays of measured quantities. Incorrect quantity display is a clear indication that something is wrong, either in the relay itself or the input circuits.

## **MAINTENANCE TESTS**

Primary injection tests are typically completed during initial commissioning. If configuration maloperation has happened and the protection relays involved are suspect, or changes have been made involving the wiring to the protection relays from the VTs/CTs, the primary injection tests may have to be repeated. Secondary injection tests may be completed at appropriate intervals to verify relay performance, and, if possible, the protection relay should be allowed to trip the involved circuit breakers. The interval between tests will depend upon the criticality of the circuit, the availability of the circuit for testing and the relay technology. Secondary injection testing is only

mandatory on the chosen relay setting and the results should be verified against those obtained during the initial equipment commissioning. It is better not to interfere with protection relay contacts at all unless they are obviously corroded. The contact performance is completely verified when the protection relay is actuated. Insulation tests should also be completed on the protection relay wiring to ground and between circuits, using a 1000V tester. These tests are mandatory to discover any deterioration in the insulation resistance.

## **PROTECTION CONFIGURATION DESIGN FOR MAINTENANCE**

If the following principles are adhered to, the danger of back-feeds is decreased and fault investigation is simplified:

- circuits should be kept as electrically separate as possible, and the use of common wires should be avoided, except where these are vital to the proper functioning of the circuits
- test blocks should be used to allow a test plug to be used, and a defective unit to be promptly replaced without interrupting service
- power supplies to protection configurations should be segregated from those feeding other equipment and equipped with completely discriminative circuit protection
- a single auxiliary switch should not be installed for interrupting or closing more than one circuit
- terminations in protection relay panels demand good access, as these may have to be changed if extensions are made. Modern panels are equipped with special test facilities, so that connections do not need to be disturbed during routine testing
- all wiring should be ferruled for identification
- electromechanical protection relays should have high operating and restraint torques and high contact pressures. Jewel bearings should be shrouded to exclude dust and the application of very thin wire for coils and connections should be avoided. Dust-tight cases with an proper breather are vital on these types of electromechanical element

- each circuit group which is electrically separate from other circuits should be grounded through an independent ground link
- where a common voltage transformer or DC supply is used for supplying few circuits, each circuit should be supplied through separate links or fuses. Withdrawal of these should totally isolate the concerned circuit
- junction boxes should be of proper size and, if outdoors, must be made waterproof
- static, digital and numerical protection relays should have test facilities to help in locating the fault. The protection relay manual should clearly present the expected results at each test point